

195

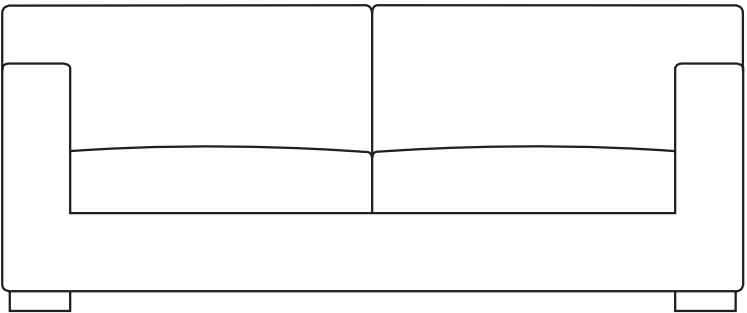

215

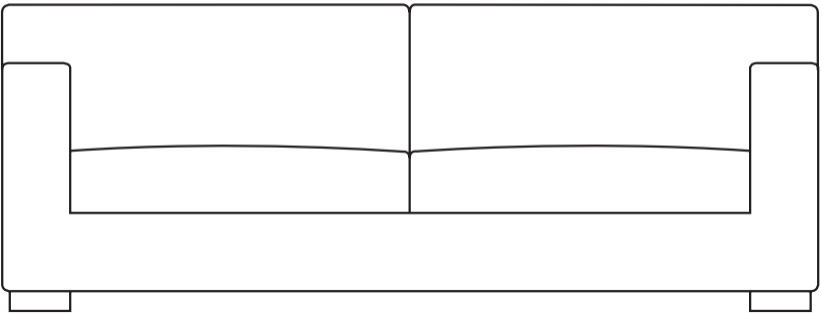

235

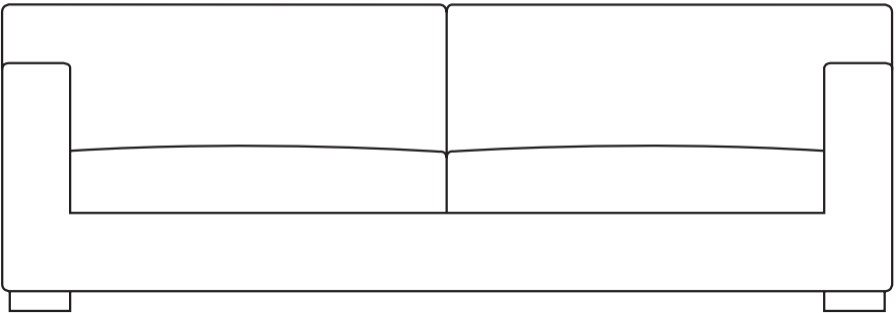

94

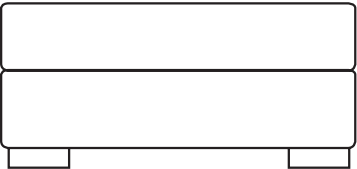

43



94

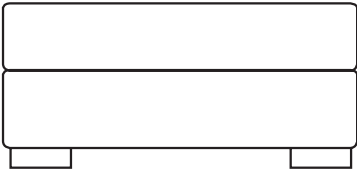

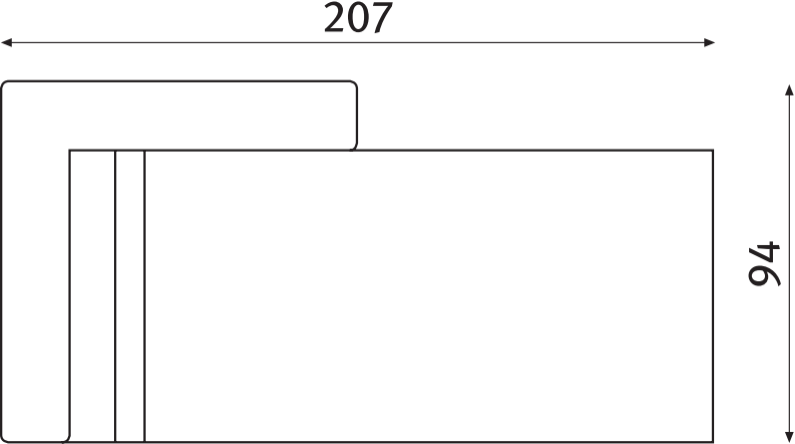

238

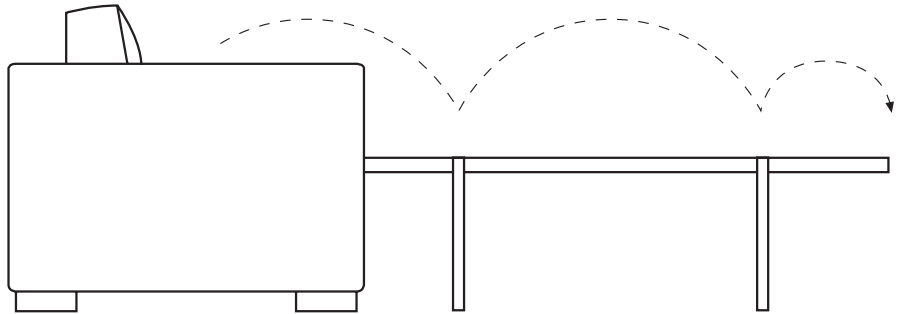

157

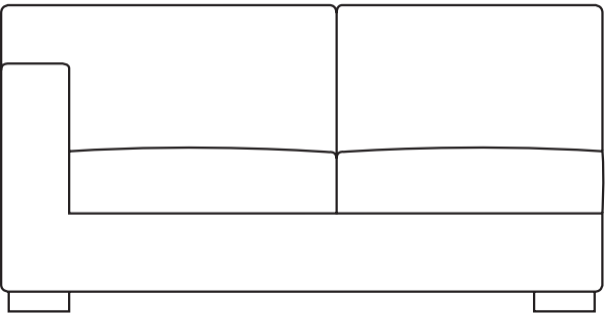

177

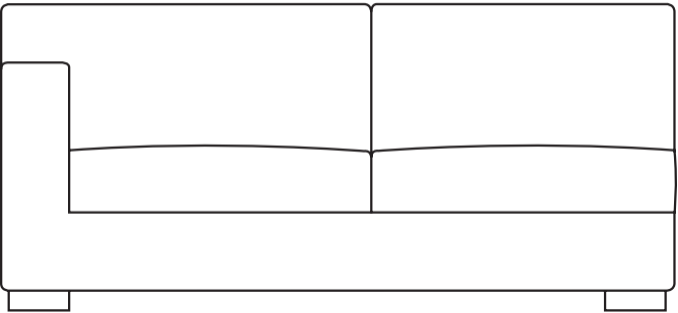

197

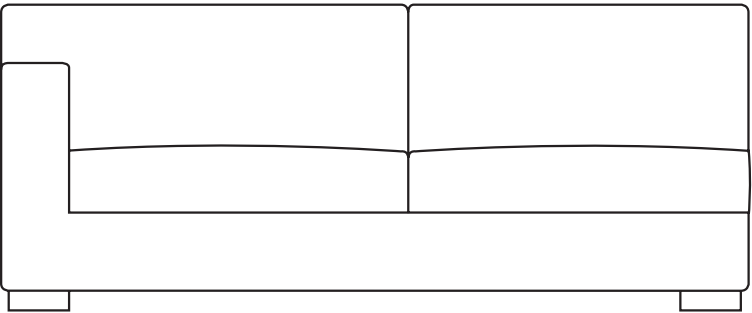

217

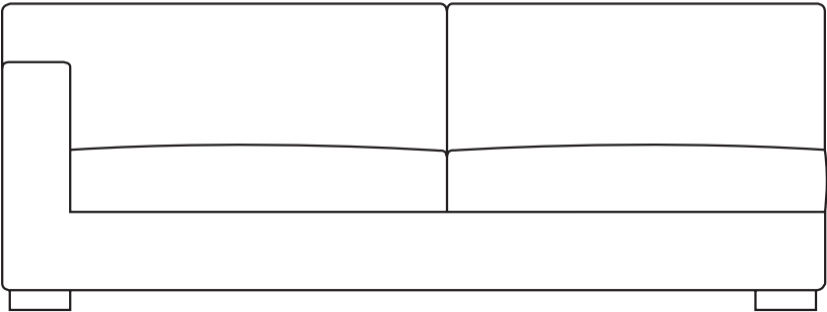

115

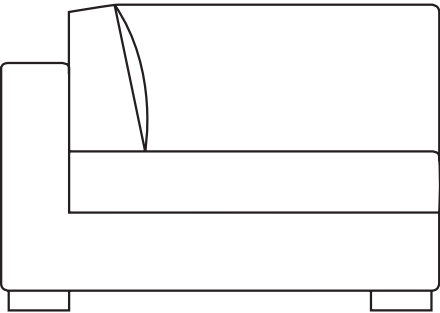

81



94

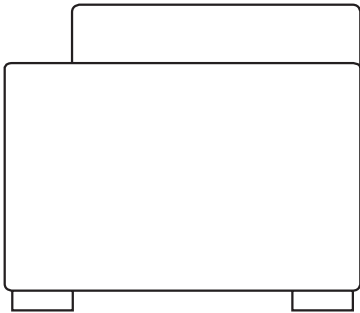

43

